



香港教育工作者聯會
Hong Kong Federation of Education Workers

香港教育工作者聯會2023 新入職教師分享講座

「識」教「識」學，教「識」學「識」

多元創新策略培育學生香港根、中國心、世界觀
公民與社會科的教學實踐

潘晨健老師
創意教師協會





01



#是日分享重點

Stay Hungry! Stay Foolish !

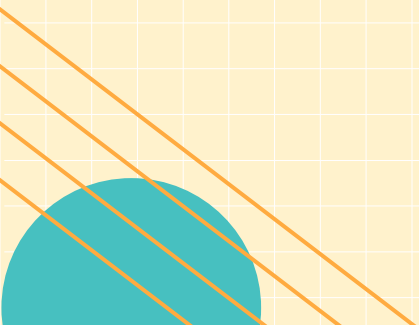
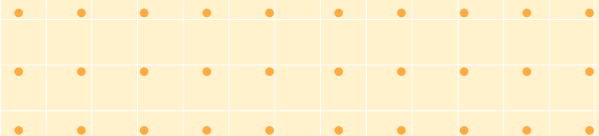
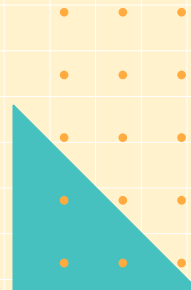
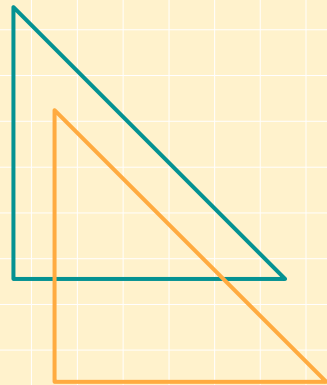

是日分享重點



公社科 / PSHE 教師
軟硬技能



多元創新學與教策略



今後的教學策略

Stay Hungry! Stay Foolish !

前瞻學生的需要

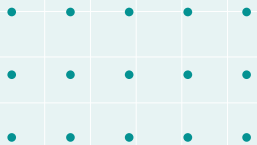

教學歷程



副教師 > 合約教師



> 常額教師



> 科主任

Stay Hungry! Stay Foolish !



潘晨健老師

I do more than teaching, I share, I inspire



教學歷程
To teach

- 執教科目：綜合人文、通識教育、公民與社會發展
- 行政組別：德育、公民與國民教育組、訓導及輔導組

教學理念
以心教，以身教
To share

- **S**hared value for society
重視建構學生共享學習成果
- **H**olistic approach for students
重視學生全人發展
- **A**utonomous learner for future
重視建構學生自主學習
- **R**ational thinking for people
重視建構學生明辨性思考
- **E**mpathy for community
重視培養學生同理心

教學目標
啟發學生，師生同行
To inspire

- **I**nspiration to students
致力啟發每位學生
- **N**eeds of each student
照顧每位學生學習需要
- **S**uccess in facilitating education
成功推動教育可持續發展
- **P**assion for perfection
止於教育至善，力臻完善
- **I**nnovation for future
推動教育創新為未來
- **R**e-energize education
重燃教育原動力
- **E**ndeavour for social betterment
誠心推動社區更好發展



02



公社科 / 個人、社會及人文
教育學習領域教師軟硬技能

Stay Hungry! Stay Foolish !

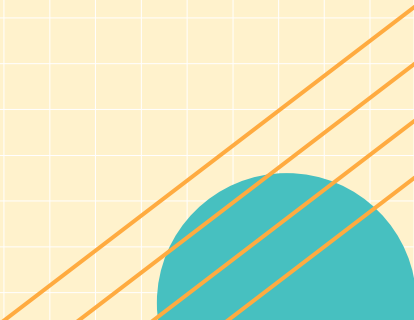
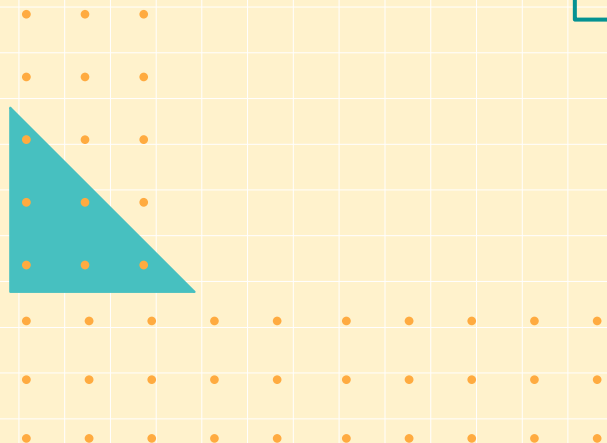

中學教育最新的七個學習宗旨 (教育局)



首要培育的價值觀和態度及國家安全教育 (教育局)



個人、社會及人文教育學習領域



圖 1：個人、社會及人文教育學習領域課程六個範疇與各初中人文科目的關係



裝備學生立足未來 建構香港根、中國心、世界觀

綜觀目前全球局勢 VUCA

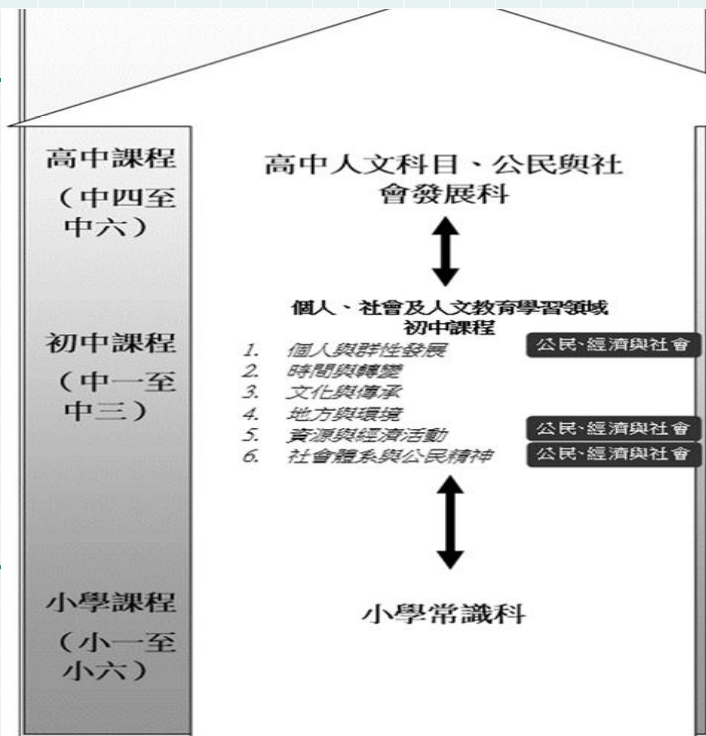
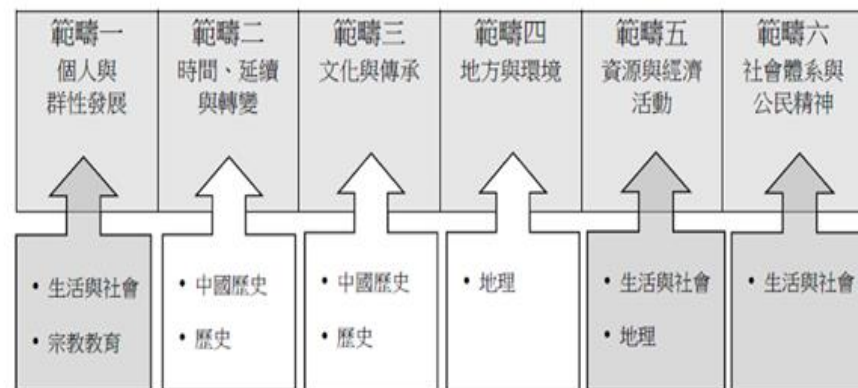
Volatility
易變性



Uncertainty
不確定性



Complexity
複雜性



Ambiguity
模糊性



公社科/ PSHE

Vitality
活力



Understanding
認知

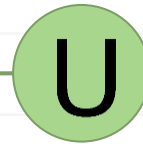

Creativity
創意



Autonomous learner
自主學習者

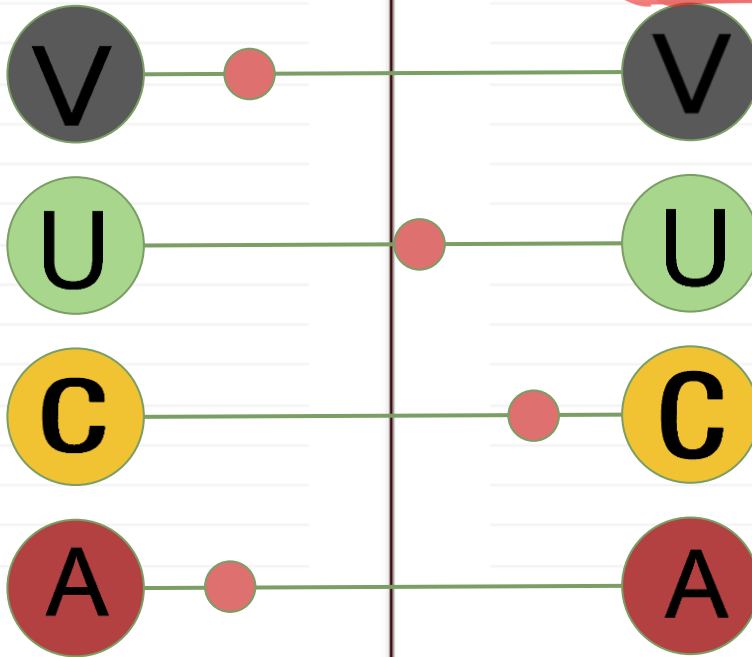

公社科 / 個人、社會及人文教育學習領域教師所需策略

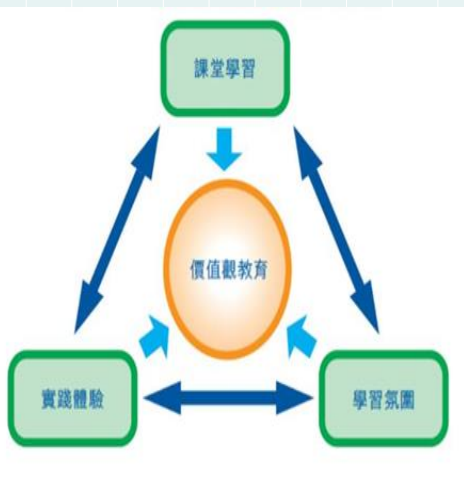

多重策略



有機結合



自然連繫



03



多元創新學與教策略

Stay Hungry! Stay Foolish !

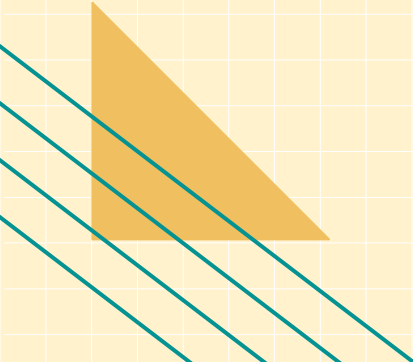

科組校本公社科教學理念

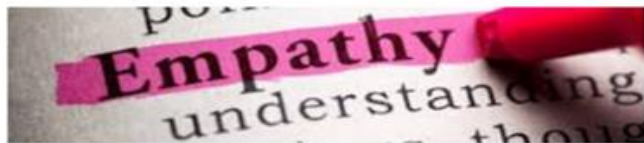

Y: Yes, I can do it!

- Sense of achievement
- Cater for learning diversity
- Caring learning environment

H: Humility

- Value education
- Life education
- Stay Hungry
- Stay foolish
- 21st century learner

T: Technology

- STEM (Science, Technology, Engineering, Mathematics)
- Autonomous learners
- E-learning : flipped classroom



Citizenship and Social Development

E: Environment

- Sustainable development
- Intragenerational fairness
- Intergenerational fairness
- Rights and obligations
- Global citizenship

M: Multiculturalism

- Local vision
- National vision
- Global vision
- Cultural appreciation
- Global citizenship

P: Positive thinking

- Appreciation
- People-oriented
- Value education
- Life-long learner
- Career planning

A: Analytical thinking

- Independent thinking
- Rational thinking
- Multiple perspectives
- Reflective
- Respect

本校公社科特色 (1)

深化學生香港根的初心

識法、守法、傳法

非華語生積極參與短片比賽
探討本地種族議題

短片創作 鼓勵少數族裔關心社會

公民責任和法治意識都是價值觀

最後，中四接近年級同學參與了比賽

Development
of
rule of law

教育研究獎勵計劃 (2022/23)

本人答允在 2023 年 8 月 31 日或之前，按秘書處提供的格式指引和要求，提交以中文或英文撰寫的教育研究報告——「探討重塑『新翻轉課堂』對提升非華語生自主學習動機的成效 --- 新高中公民與社會發展科校本經驗實踐的行動研究」。

重新翻轉課堂
有機結合、自然連繫
公社科課程宗旨

Development
of
rule of law



學生拍攝形式：

- 邀請老師訪談、簡報拍攝、自拍……

建構共享學習資源平台：

- 學生將短片上載在Google classroom

重塑新翻轉課堂的教學策略 (學術理論)

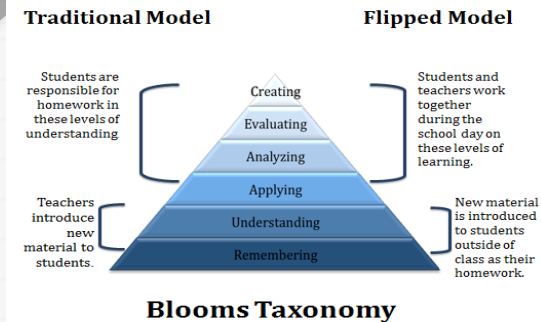

Blooms Taxonomy	重塑新翻轉課堂
認識	學生搜集資料
應用	學生草擬拍攝素材
分析	學生辨別資料真偽
創造	學生拍攝預習短片

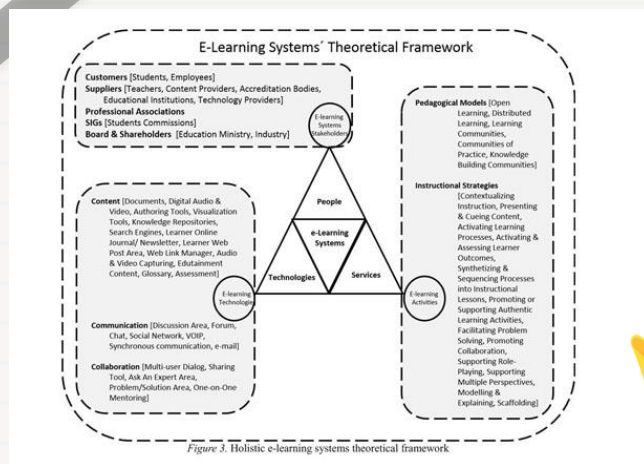

- 重塑新翻轉課堂重視學生與電子平台的結合
- 但各式各樣的電子平台及工具例如：Google classroom, spreadsheet 在重塑新翻轉課堂只是促進學習角色
- 重塑新翻轉課堂強調以學生為本，由學生主導並引領電子平台來強化學習

裝備學生立足未來 建構香港根、中國心、世界觀

V Vitality



新常態下的共通技能

- 製片技能、拍片技能
- 學生透過資料搜集深化慎思明辨能力



牢不可破的價值觀

- 學生拍攝短片並上傳於平台上分享學習成果，建構共享價值

C Creativity



立足未來的態度

透過拍攝預習短片，學生積極學習、求知若飢

U Understanding



新常態下的共通技能

- 學生透過拍片前預習主題深化學科知識
- 學生藉此建立多角度思考



牢不可破的價值觀

- 學生之間互相欣賞彼此的短片，深化尊重多元文化的價值觀

A Autonomous Learner

本校公社科特色 (1)

深化學生香港根的初心

識法、守法、傳法

□ 同工引導學生思考法治及道德兩難問題

- 合法是否一定合義？
- 議題：劏房、跨性別婚姻 ……

□ 同工引導學生啟發潛能傳法

- 香港科技大學創業中心 X 心苗亞洲
社會公益創業個案競賽 (中學組冠軍)

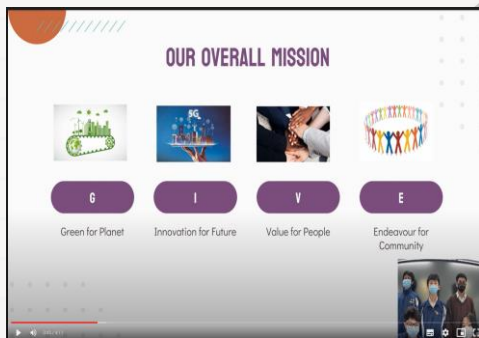

本校公社科特色 (1)

深化學生香港根的初心

校本調解課堂



第一部分 調解概述

第二部分 調解技巧

S.O.F.T.E.N. Skills

- Smile 微笑
- Open 開放
- Forward leaning 向前傾斜
- Touch 觸摸
- Eye contact 眼睛接觸
- Nod 點頭

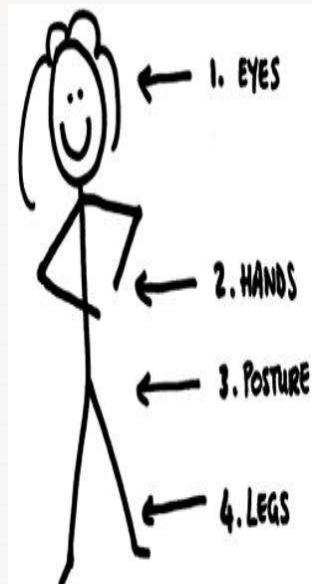

本校公社科特色 (2) 深化學生的家國情懷 國家安全法、憲法



本校公社科特色 (2) 深化學生的家國情懷 國家安全法、憲法

中四公民與社會發展科 54 Citizenship and Social Development
以「讀」或「讀」自主學習系列 (一)：公讀 (公社科九宮格) CSDdoku
10 小辣入門版 Level 10 Mild Spicy version

姓名 Name: _____ () 級別 Class: _____ 堂級 1st / 進修 2nd / 加果第 次

◆ 同學宜在一至兩分鐘內列出與一國兩制相關的概念。
List the relevant concepts related to One Country Two Systems within 1-2 minutes.

	一國兩制 One Country Two Systems	



公社科九宮格 (CSDdoku) 譚仔分層版

照顧學生學習差異 「殊」不簡單認識法治概念

10小辣入門版(淺)	只需填寫相關概念
中辣入場版(中)	按次序填寫概念
大辣闖關版(難)	填寫跨單元概念



本校公社科特色 (2) 深化學生的家國情懷 國家安全法、憲法

2022-2023 中四、五公民與社會發展科 S4-S5 Citizenship and Social Development
以「讀」攻「讀」自主學習系列 (二): 公讀 (公社科九宮格) CSDdoku
10 小辣入門版參考角度 Suggested version of Level 10 Mild Spicy

- ◇ 同學宜在一至兩分鐘內列出與國家安全相關的概念。
List the relevant concepts related to national security within 1-2 minutes.

政治安全 Political security	國土安全 Homeland security	軍事安全 Military security
網絡安全 cyber security	國家安全 National security	經濟安全 Economic security
科技安全 science and technology security	社會安全 Public security	文化安全 Cultural security

- 以上只是參考角度，同學只要提供合乎課程主題綱要的概念，言之成理，皆可接受。
The above version is some suggested angles. Other reasonable and possible concepts with reference to the CSD curriculum and assessment guide are also accepted.

培育學生家國情懷



Your Performance: 



Name: _____
Historical Incident: Lin Zexu
banned _____

◆ What can I learn from him?

本校公社科特色 (3)

強化學生的世界觀

全球環保法規



華彩集團有限公司 (上集) Brilliant Printing Limited

本輯資料

- 企業嘉賓：史立德博士 BBS MH 太平紳士
華彩集團主席
- 校長點評：劉世蒼校長，廠商會蔡章閣中學
- 撰文學生：陳雅暉同學 (3B)，廠商會蔡章閣中學

學生文章

華彩集團主席史立德博士 BBS MH 太平紳士的分享片段，改變了我一直以來對印刷行業的固有印象，亦令我更加認識到印刷行業的社會責任、企業與環境保護及可持續發展的重要聯繫。

說實話，我以往並不知道現今印刷行業的生產細節，仍然抱有一個印象就是造紙印刷往往要砍伐大量樹木，但我萬萬想不到用石頭也可以造紙，這樣不但可以減少砍伐樹木，同時又能夠促進綠色環境。保護大自然、減廢、罕罕得、罕罕得、罕罕得往往透過腳印已經用上不少紙張，香港有那麼多學生，要使用那麼多紙張，豈不是多麼多樹木都不夠砍伐嗎？如果造紙和印刷行業還保持舊式的生產模式，地球資源耗盡只是時間的問題。這段影片分享令我了解到原來業界會因應時代環境的變遷而優化造紙技術，改變了我對印刷行業的舊有印象。

與此同時，我亦認知到印刷行業的企業社會責任。可能人們經常會說企業就是要做到利潤最大化，為股東謀求最大利益，但史立德博士指出了，其實在推動環境保護及可持續發展的同時，公司自身亦能夠從中得益，例如節省用電不但令成本下降，亦能夠對企業形象帶來正面作用，保護到環境之餘，公司也有得益。由此可見，企業社會責任與環境保護的確可以帶來雙贏局面。

企業嘉賓回贈

的確，華彩集團有限公司一直重視可持續發展的環保包裝，致力在商界推動環保。我們相信透過永續發展才能夠為企業以至全球人類的福祉帶來雙贏。

校長點評

為何創新？創新的目標是改善生活、促進發展、保育環境。學生體會造紙需要大量砍伐樹木，最終耗盡地球資源。技術革新令學生改變印刷行業的舊有印象，注入新思維，明白企業創新能為環境保護及可持續發展帶來莫大幫助。

關鍵字

文化 # 印刷 # 企業社會責任 # 可持續發展



企業資料

地址：香港新界荃灣青山道 388 號中裕大廈 10 樓 1001 室
電話：(852) 2614 0800
網址：<http://www.brilliant-group.com/>
傳真：(852) 2614 6367



This project is funded by the Sustainable Development Fund 離境計劃由可持續發展基金資助

21.3 國際消除種族歧視日



推動平等 不分你我
#IDERD #FIGHTRACISM #EOC4EQUALITY
EMIRAKE

多重策略深化學生香港根、中國心、世界觀



香港根



家國情



國際觀

Stay Hungry! Stay Foolish !





04

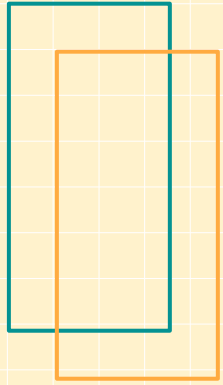

今後的教學策略

Stay Hungry! Stay Foolish !

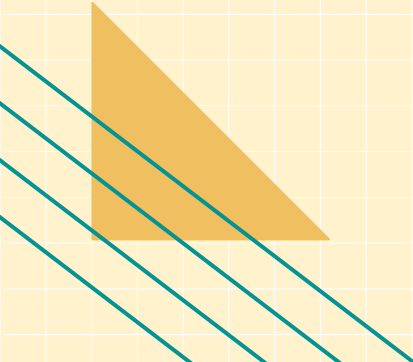



4 Key Elements of Cross-curriculum approach

1

CS (Citizenship and Social Development)

- Flipped Classroom
- CSdoku
- Use of graphic organizers
- Tiered assignments
- Multiple assessment approaches such as video making, slogan design, poster design, model design, re-write the lyrics
- Role play competition
- Debating competition
- Mainland Study Tour --- Mini exhibition of students learning outcomes



2

PSHE (Personal, Social & Humanities Education)

- Drama in junior forms (IH X Chi Hist)
- Mediation competition in senior forms (CS X CDD X MCNE)
- Mainland Study Tour / Exchange programme (CS X GEO X MCNE)
- Multiple assessment approaches such as video making, slogan design, poster design, model design, re-write the lyrics (CS X GEO X THS X IH X Chi Hist)



3

Value Education

- Enriched Basic Law Education (Multiple strategies such as case comparisons with different contexts)
- Enriched Constitution Education (Multiple strategies such as case comparisons with different contexts)
- Empathy Role-play, charity activities, CYC activities



4

Language Across the Curriculum (LAC)

- LAC school-based handouts for CMI classes IH / Citizenship, Economics and Society (New subject) X ENG
- LAC school-based activities English cafe / Tea time



By PS

傳承師德，燃亮生命



- 傳承宗旨
 - 以心教，以身教
 - 教學相長，砥礪同行
- 教學層面
 - 摒棄固有思維，互相分享教學點子
- 推動教育創新層面
 - 積極參與學界的分享會，並與同工一起探究不同教學法在本校推動的可塑性
 - 積極以「小步子」形式帶領同工一起落實創新教學法
- **Inspiration to students** 致力啟發每位學生
 - 相信每位學生獨有的潛能，為學生締造成功感
- **Needs of each student** 照顧每位學生學習需要
 - 推動評核模式多元化及創新化，與每位學生同行
- **Success in facilitating education** 推動教育可持續發展
 - 培養學生自主學習精神，成為自主學習的主人翁
- **Passion for perfection** 止於教育至善，力臻完善
 - 定期檢討學與教效能，透過自省促進學與教
- **Innovation for future** 推動教育創新為未來
 - 積極裝備自己，推動創新教學法
- **Re-energize education** 重燃教育原動力
 - 勿忘教學初心，積極迎接挑戰
- **Endeavour for social betterment** 誠心推動社區發展
 - 與學生同行，裝備學生迎接今後VUCA的挑戰

請記得 留住師生同行的感覺 過渡在人海



<https://www.youtube.com/watch?v=29CmGbPXa2o>

共勉之 # 同為香港教育譜新篇

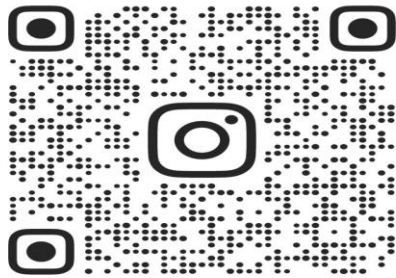

@ROY.POON.LS.CSD

